

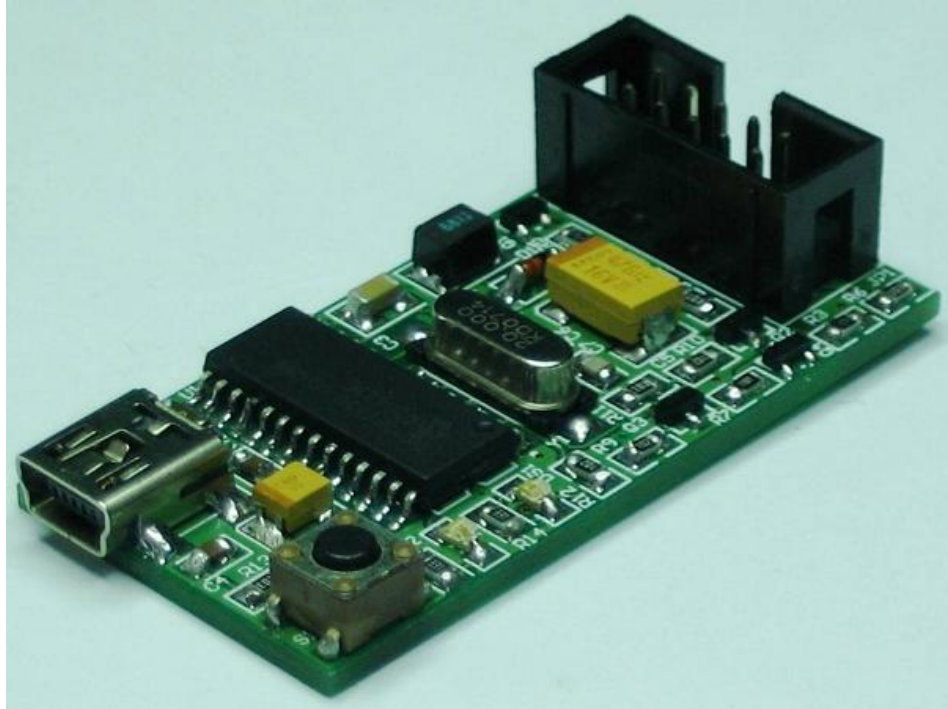

UIC00A USB ICSP PIC PROGRAMMER



User's Manual

V1.7

Nov 2008

Information contained in this publication regarding device applications and the like is intended through suggestion only and may be superseded by updates. It is your responsibility to ensure that your application meets with your specifications. No representation or warranty is given and no liability is assumed by Cytron Technologies Incorporated with respect to the accuracy or use of such information, or infringement of patents or other intellectual property rights arising from such use or otherwise. Use of Cytron Technologies's products as critical components in life support systems is not authorized except with express written approval by Cytron Technologies. No licenses are conveyed, implicitly or otherwise, under any intellectual property rights.

Index

1. Introduction and Overview	1
2. Packaging List	2
3. Supported PIC	3
4. Board Layout	5
5. Installation (hardware)	6
5.1 Using UIC00A with application circuit (development board)	6
5.2 Using UIC00A with UIC-S (optional, buy separately)	7
5.2.1 Plugging the microcontroller	8
6. Installation (software)	11
7. Getting Started	15
7.1 Using PICKit 2 Programmer Software	15
7.2 Using UIC00A	26
7.2.1 Using UIC00A with application circuit (development board)	27
7.2.2 Using UIC00A with UIC-S (optional, buy separately)	29
7.3 Troubleshooting	30
8. Warranty (6 months)	31

1. INTRODUCTION AND OVERVIEW

UIC00A offers low cost yet reliable and user friendly PIC USB programmer solutions for developer, hobbyist and students. It is designed to program popular Flash PIC MCU which includes PIC12F, PIC16F and PIC18F family. It can also program 16bit PIC MCU. On board ICSP™ (In Circuit Serial Programming) connector offers flexible method to load program. It supports on board programming which eliminate the frustration of plug-in and plug-out of PIC MCU. This also allow user to quickly program and debug the source code while the target PIC is on the development board. Since USB port is commonly available and widely used on Laptop and Desktop PC, UIC00A is designed to be plug and play with USB connection. This programmer obtained it power directly from USB connection, thus **NO external power supply** is required, making it a truly portable programmer. This programmer is ideal for field and general usage. UIC00A offers reliable, high speed programming and free windows interface software.

It is designed with capabilities and features of:

- Industrial grade PCB with surface mount component to offer small size yet reliable and quality product.
- Every component is soldered properly and programmer is tested before it is shipped to customer.
- USB Plug and Play function.
- IDC box header for ICSP™ connection, an IDC cable is included for external on board programming.
- Windows XP compatible software.
- **Compatible with Windows Vista***.
- Auto load program capability.
- Compatible with Microchip's PICkit 2.
- **Optional external power to target PIC should be +5V.**
- Small size of **5cm x 2.5cm.**
- Powered directly from USB port.
- **NO EXTERNAL POWER REQUIRED for UIC00A to function.**
- USB 2.0
- Low cost yet reliable solution.
- Suitable for Laptop and Desktop PC.
- Optional socket (UIC-S) to program 18 pins, 28 pins and 40 pins PIC microcontroller.

*UIC00A has been tested on several editions of Windows Vista. If user found it is not compatible, we will offer money back guarantee (need to be shipped back within 3 days from receiving date, shipping is not included).

This document explains the method to use UIC00A.

2. PACKAGING LIST

Please check the parts and components according to the packing list. If there are any parts missing, please contact us at sales@cytron.com.my immediately.

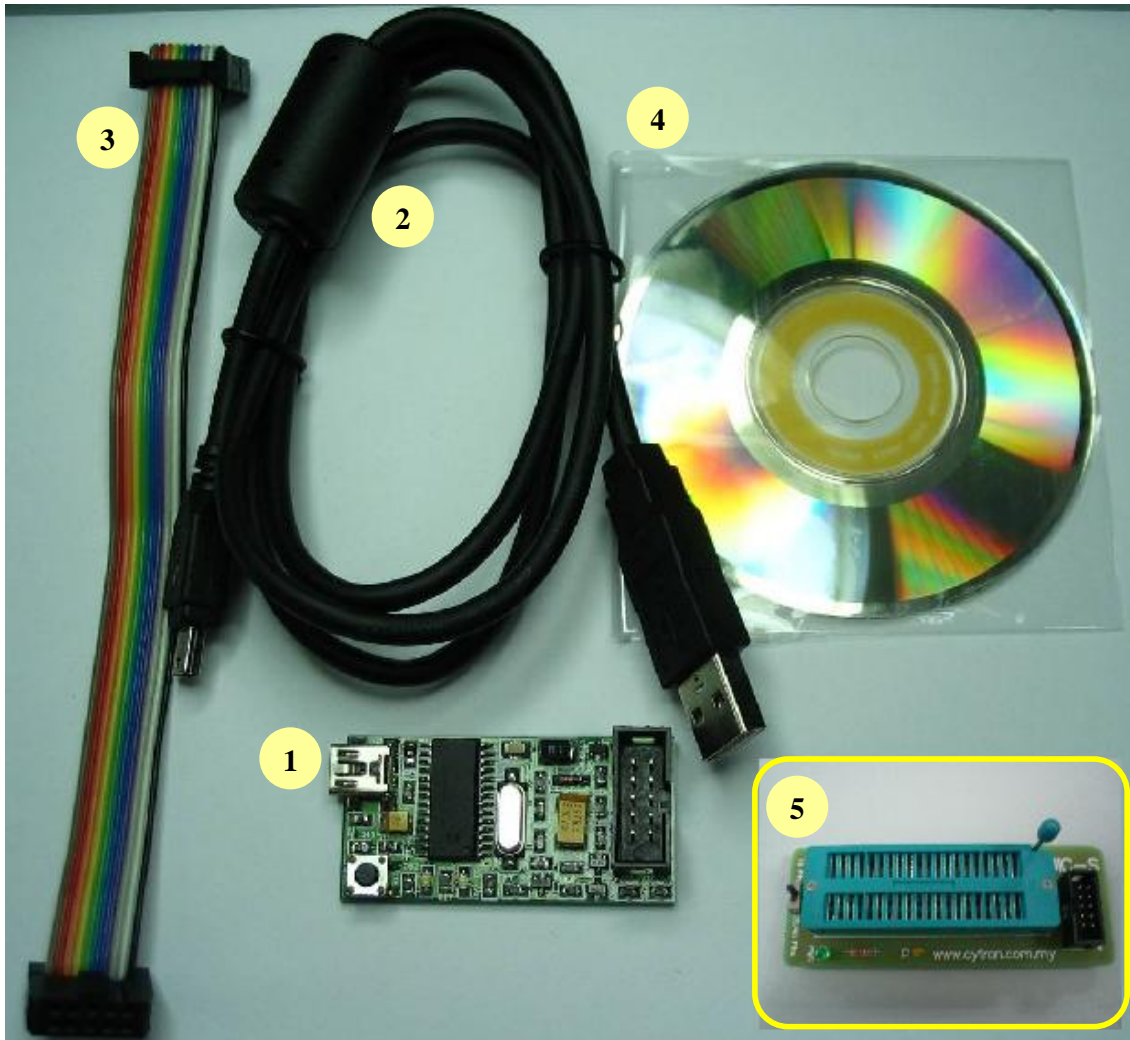

1. 1 x UIC00A main board
2. 1 x mini USB cable
3. 1 x rainbow cable (programming cable)
4. 1 x Software Installation and User's Manual CD
5. 1 x UIC-S socket board (optional, buy separately from Cytron website)

3. SUPPORTED PIC

UIC00A is compatible with PICkit 2 programmer software. It has been tested to load program using UIC-S socket board. Below are the PIC models that being tested using UIC00A:

Mid range devices	18F devices	dsPIC devices
PIC16F777	PIC18LF4539	dsPIC30F1010
PIC16F877	PIC18F4320	dsPIC30F2010
PIC16F76	PIC18F2320	dsPIC30F2011
PIC16F74	PIC18F448	dsPIC30F2012
PIC16F747	PIC18F4331	dsPIC30F2020
PIC16F886	PIC18F2420	dsPIC30F3010
PIC16F916	PIC18F2320	dsPIC30F3011
PIC16F737	PIC18F2523	dsPIC30F3012
PIC16F73	PIC18LF2550	dsPIC30F3013
PIC16F767	PIC18F2682	dsPIC30F3014
PIC16F627A	PIC18F1330	dsPIC30F4011
PIC16F873A	PIC18F4220	dsPIC30F4012
PIC16F627	PIC18LF4520	dsPIC30F4013
PIC16F84A	PIC18F2423	
PIC16LF84A	PIC18F252	
PIC16F84A	PIC18LF252	
PIC16f506	PIC18F4420	
PIC16F616	PIC18F458	
PIC16F627	PIC18F2610	
PIC16F627A	PIC18F2520	
PIC16F628	PIC18F2550	
PIC16F628A	PIC18F4455	
PIC16F716	PIC18F258	
PIC16F737	PIC18F4680	
PIC16F818	PIC18F248	
PIC16LF876A	PIC18F2550	
PIC16F877A	PIC18F2455	
PIC16LF877A	PIC18F2410	
PIC16F877	PIC18F2685	
PIC16F886	PIC18F2680	
PIC16F917	PIC18F2450	
	PIC18F2525	
	PIC18F2431	
	PIC18F2685	
	PIC18F2620	
	PIC18F2221	
	PIC18F1220	
	PIC18F1230	
	PIC18F1320	
	PIC18F452	
	PIC18F2525	
	PIC18F4620	
	PIC18LF4539	
	PIC18F4550	

Test condition:

- Using UIC-S socket board.
- V_{CC} (+5V) direct from USB port.
- PIC Microcontroller: Stand alone mode.

Note: For those PIC models not listed in the table (but supported in PICKit 2 list) are **not fully tested** by Cytron Technologies with UIC00A. User is advised to ensure its compatibility.

Note: “Use Vpp First Programming Entry” is not supported by UIC00A. Therefore, PIC16F88, PIC16F87, PIC16F818, PIC16F819, PIC16F62xA, and PIC648A that is configured under condition (a), (b), and (c) is not supported by UIC00A:

- (a) It uses the internal oscillator
- (b) The MCLR pin is turned off to use as a digital input instead
- (c) The program code enabled the Timer1 Oscillator in the TICON register.

Please avoid any of the condition above to ensure UIC00A compatibility for listed PIC.

4. BOARD LAYOUT

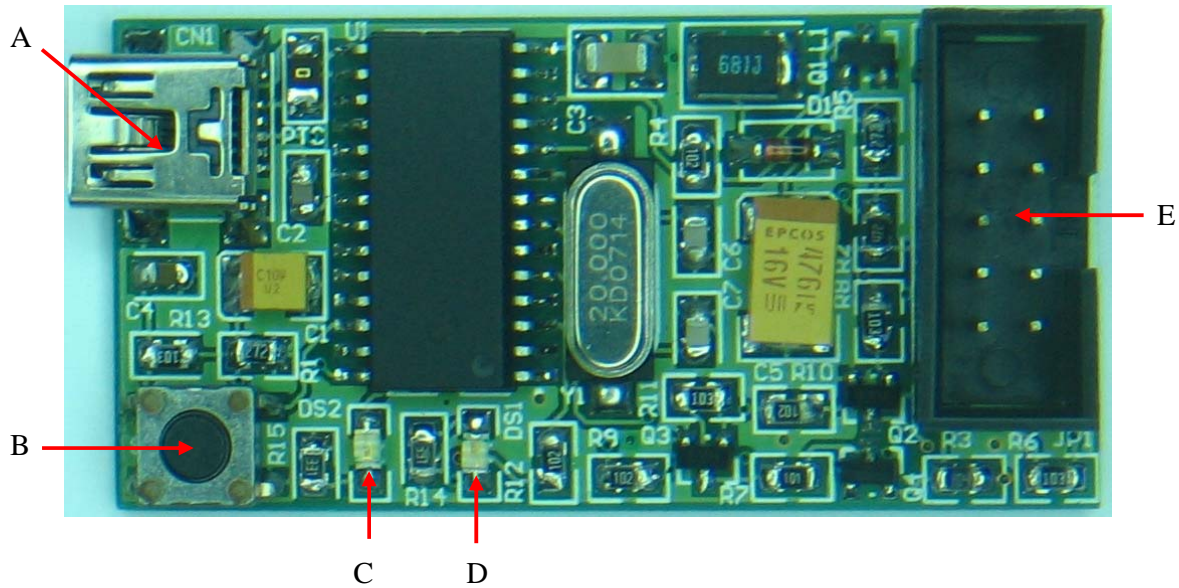

Label	Function	Label	Function
A	Mini USB port socket	D	Busy indicator LED (red)
B	Switch to initiate write device programming	E	IDC Box Header for programming connector
C	Main power supply indicator LED (green)		

Mini USB port socket at “A” is for USB connection to PC desktop or laptop. Please connect the mini header of USB cable to this socket.

Mini USB socket is not designed for frequent plug in and plug out, thus user is advise to minimize the connect/disconnect of USB cable and Mini USB socket. It is advice to disconnect it at the other end of USB cable which is USB type A. This will pro-long the life span of UIC00A.

Switch at “B” is a push button which may be used to initiate the write device function when *programmer>Write on PICkit Button* is checked.

Green LED at “C” is used to indicate the main power supply of UIC00A. It should ON once USB connection from UIC00A to computer or laptop is ready.

Red LED at “D” is used to indicate busy function such as UIC00A is in program mode or is alerting that a function is in progress.

IDC box header at “E” is for programming cable. Please connect one end of programming cable to this header, while the other end to target board. Please refer to section 7.2.1 for details pin configuration of IDC box header.

5. INSTALLATION (HARDWARE)

This section will show the connection during UIC00A usage.

5.1 Using UIC00A with application circuit (development board)

1. Connect A-type USB connector (one end of USB cable) to USB port at laptop or PC desktop.
2. Connect another end of USB cable (mini) to UIC00A USB port.
 - Power supply indication green LED will light ON.
3. Continue to software installation if this is the first time usage. Refer to section 6 for software installation guide.
4. Connect one side of programming cable to box header of UIC00A and the other side to box header of development board (target device) to be program.
 - Use external power for the target board, UIC00A cannot support large power usage.

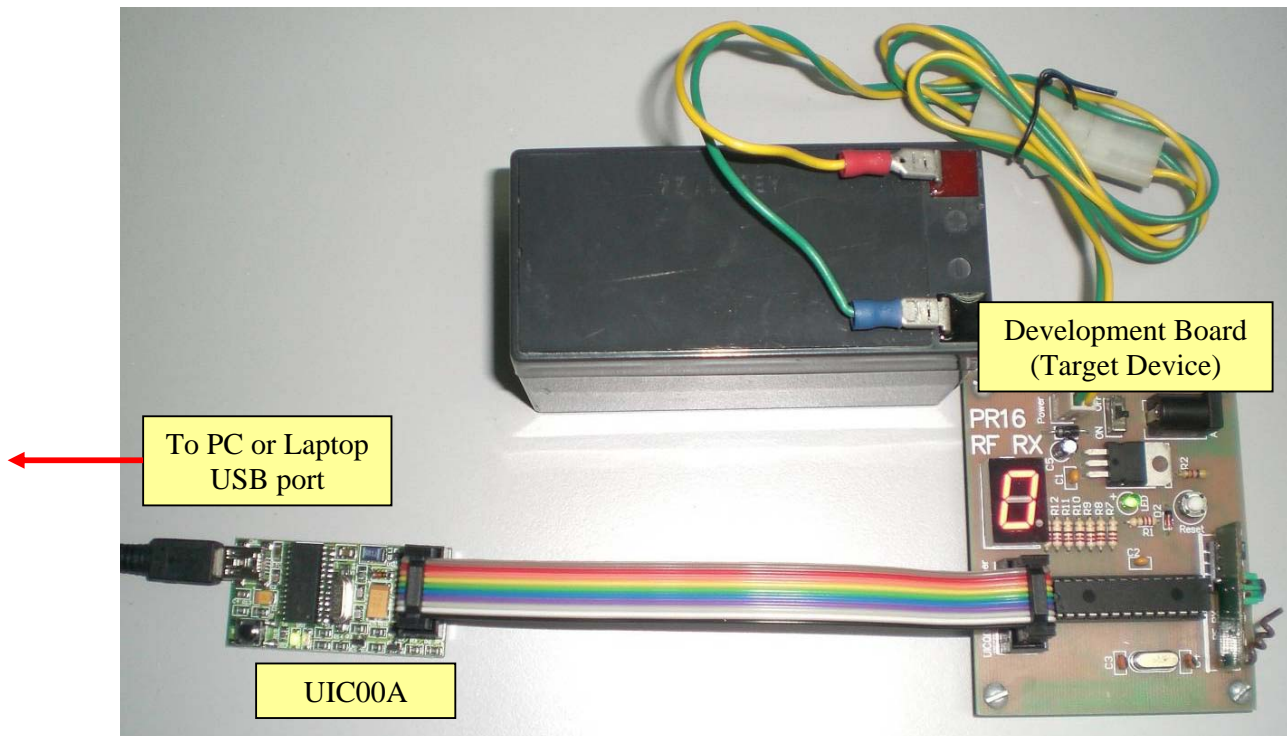

Caution: USB port current limit is 150mA. If the target and UIC00A exceed this current limit, the UIC00A board might be damaged. The target board should be powered externally.

5.2 Using UIC00A with UIC-S (optional, buy separately)

1. Connect A-type USB connector (one end of USB cable) to USB port at laptop or PC desktop.
2. Connect another end of USB cable (mini) to UIC00A USB port.
 - Power supply indication green LED will light ON.
3. Continue to software installation if this is the first time usage. Refer to section 6 for software installation guide.
4. Connect one side of programming cable to box header of UIC00A and the other side to box header of UIC-S board.
 - No external power required for UIC-S to function.

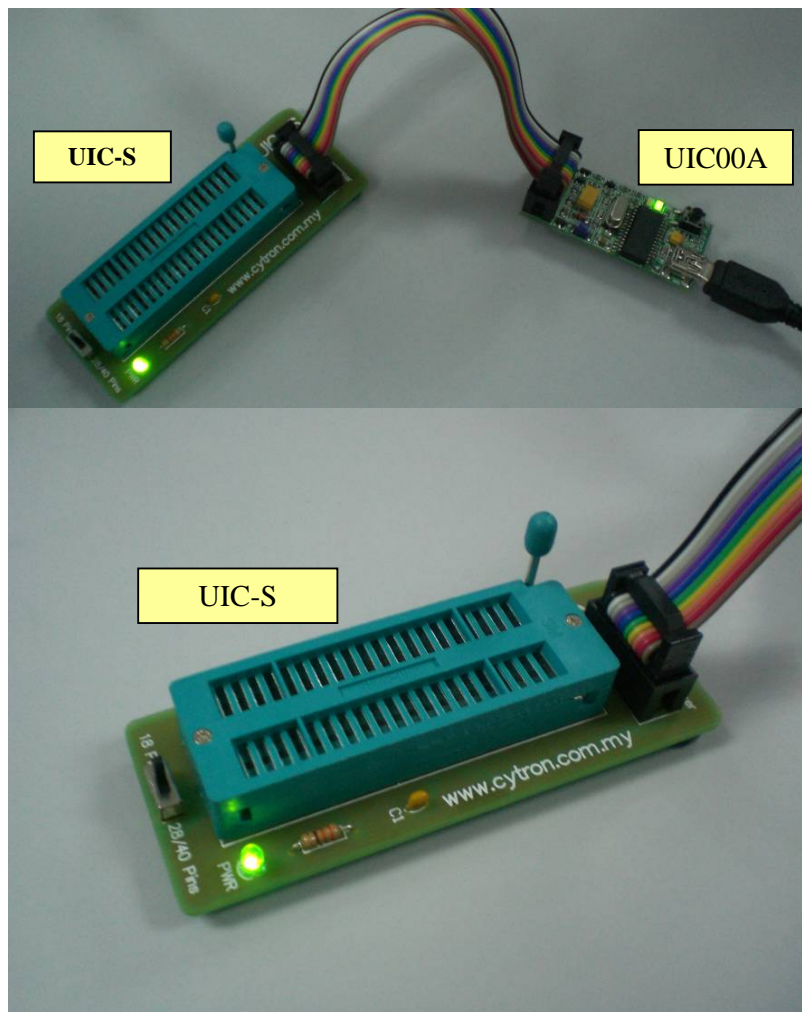

5.2.1 Plugging the microcontroller

40-pin Microcontroller

- Plug in the microcontroller at the ZIF socket and **turn the slide switch** to label “28/40 Pins” as shown below.

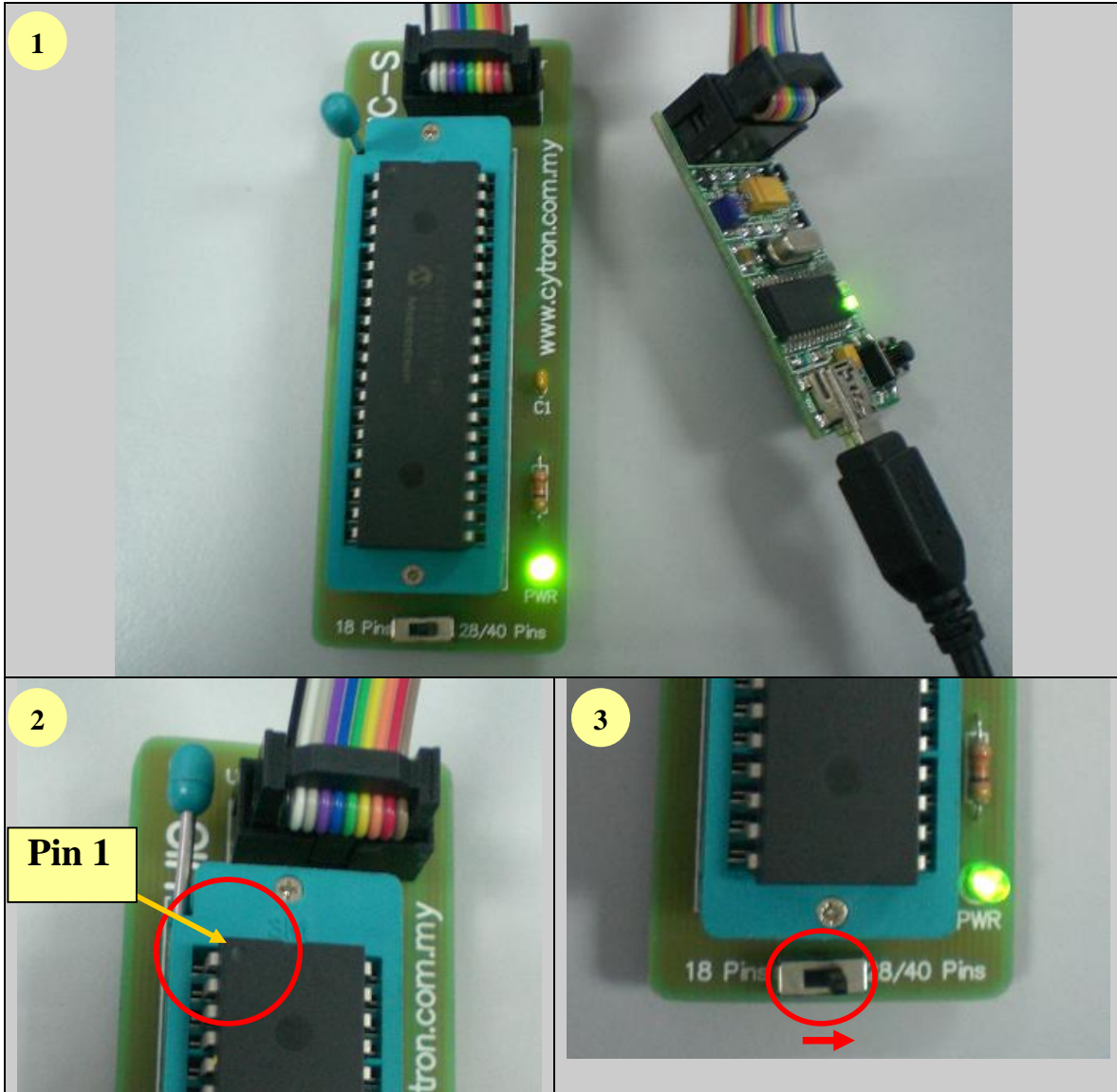

28-pin Microcontroller

- Plug in the microcontroller at the upper portion of the ZIF socket and **turn the slide switch** to label “28/40 Pins” as shown below.

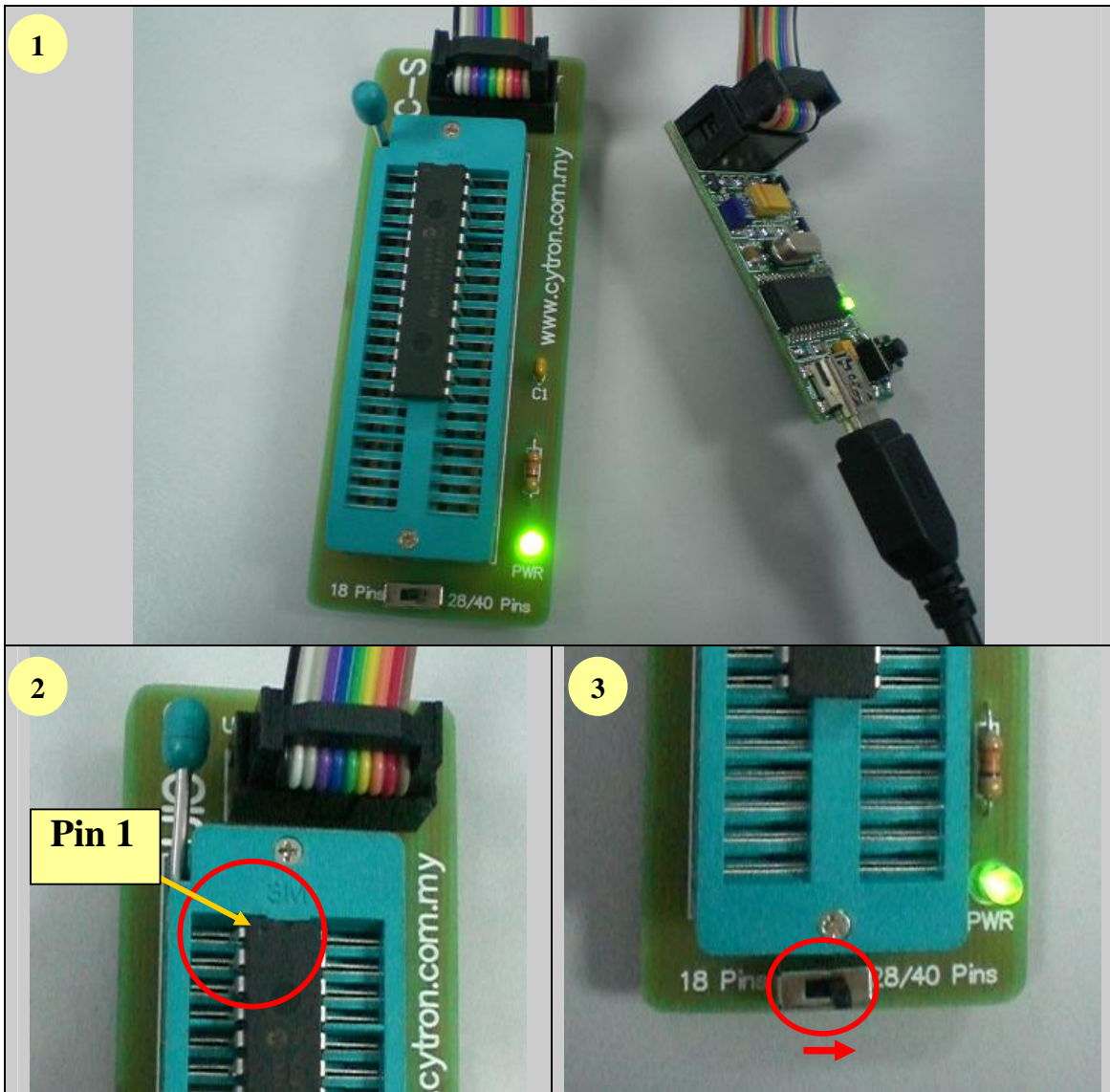

18-pin Microcontroller

- Plug in the microcontroller at the lower portion of the ZIF socket and **turn the slide switch** as shown below.

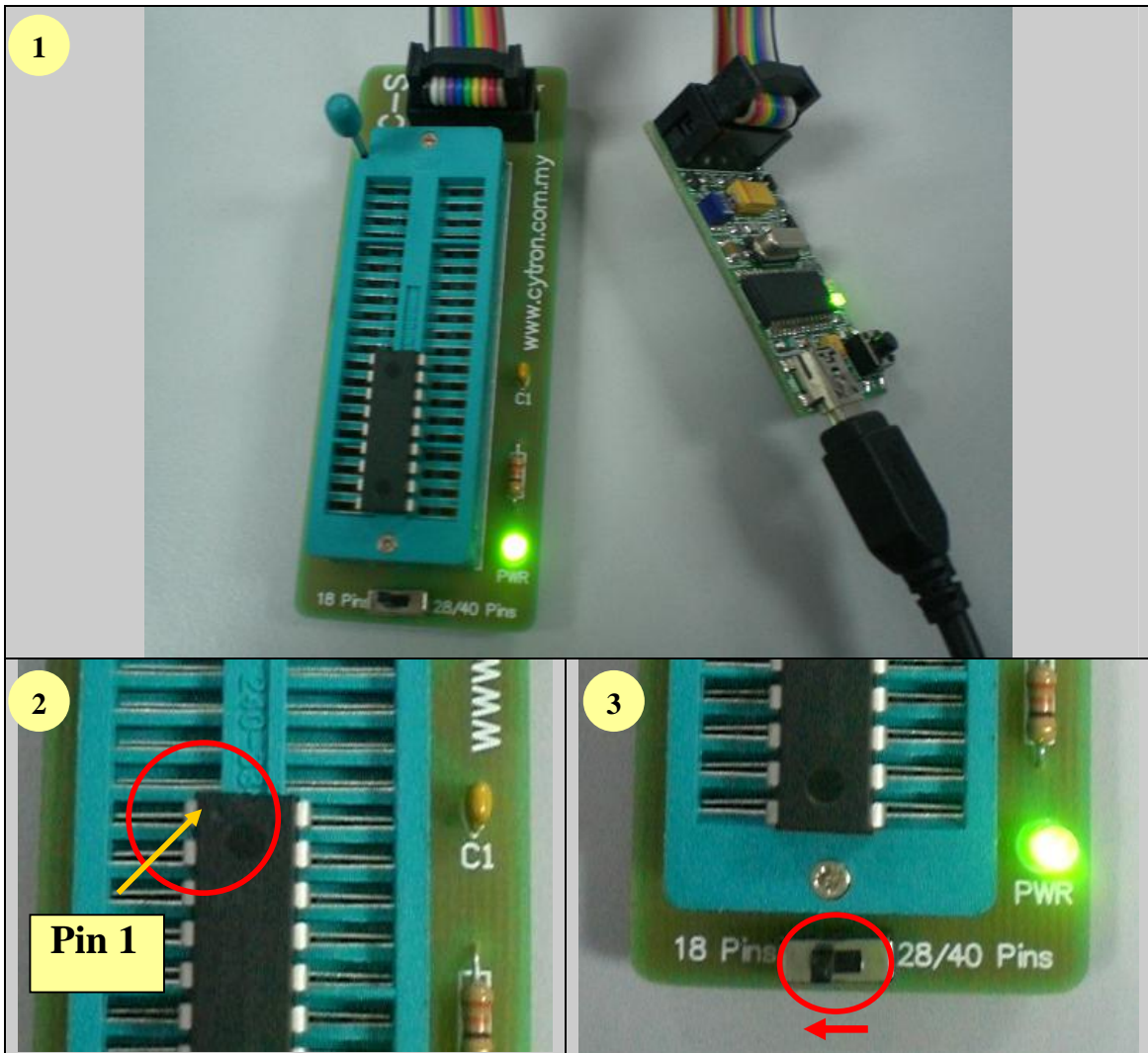

6. INSTALLATION (SOFTWARE)

Since UIC00A is compatible with PICKit 2, thus PICKit 2 programming software should be installed. With the help of pictures and some simple instruction, following section will guide to install the PICKit 2 programming software.

6.1 Install from CD

1. Place UIC00A CD in to computer or laptop CD drive.
2. Browse to folder “UIC00A Setup”.
3. Double click “setup” to run the installation wizard.

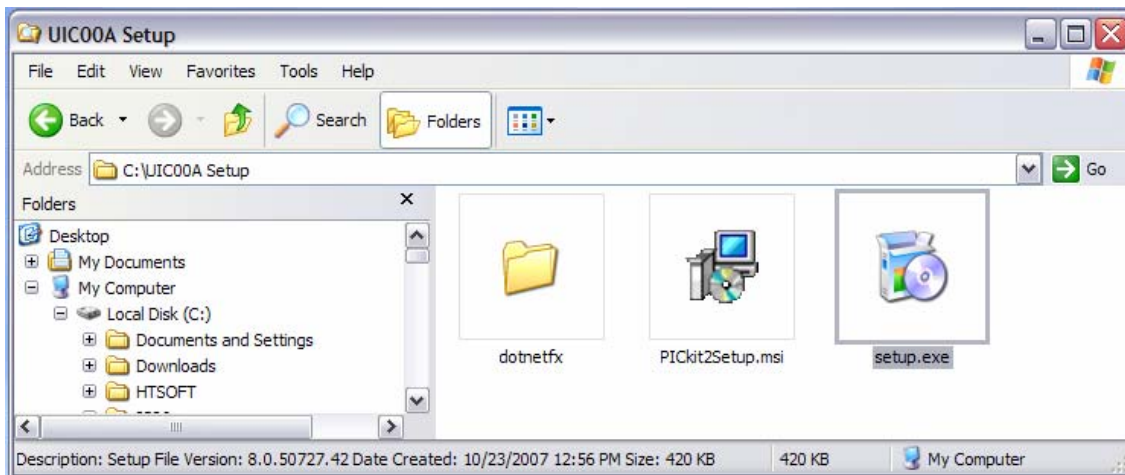

6.2 Download setup file from Cytron's website

1. User may download the setup file from Cytron's website:
2. After finish downloading, unzip the file and click “setup” to run the installation wizard.



5.3 PICkit 2 Programmer setup procedures

Follow steps below to setup Microchip PICkit2 Programmer after launched the setup file.

1. Click next.

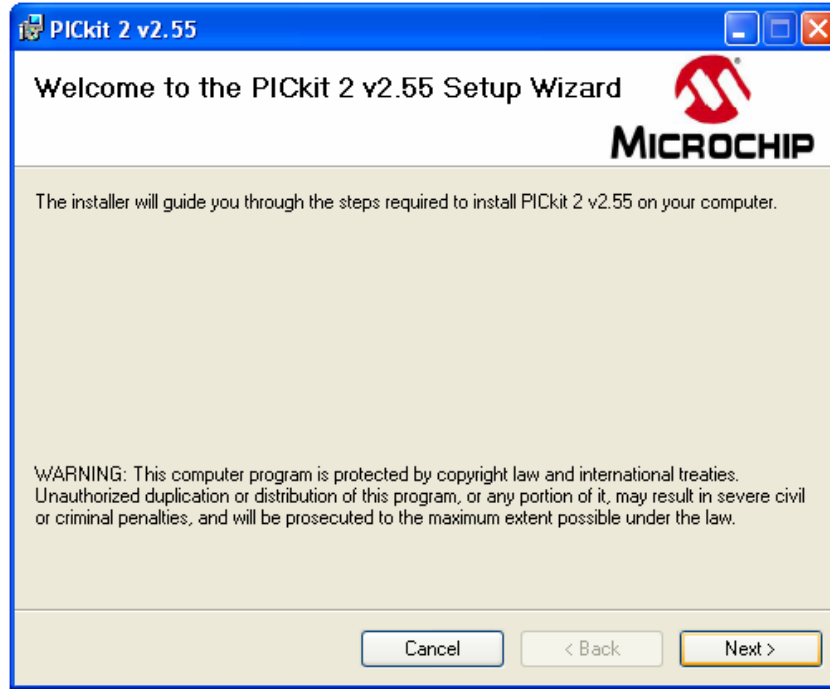

2. The following window concerns the installation folder. Click *Browse* if you want to change the default destination. Assuming change, click on *Next*.

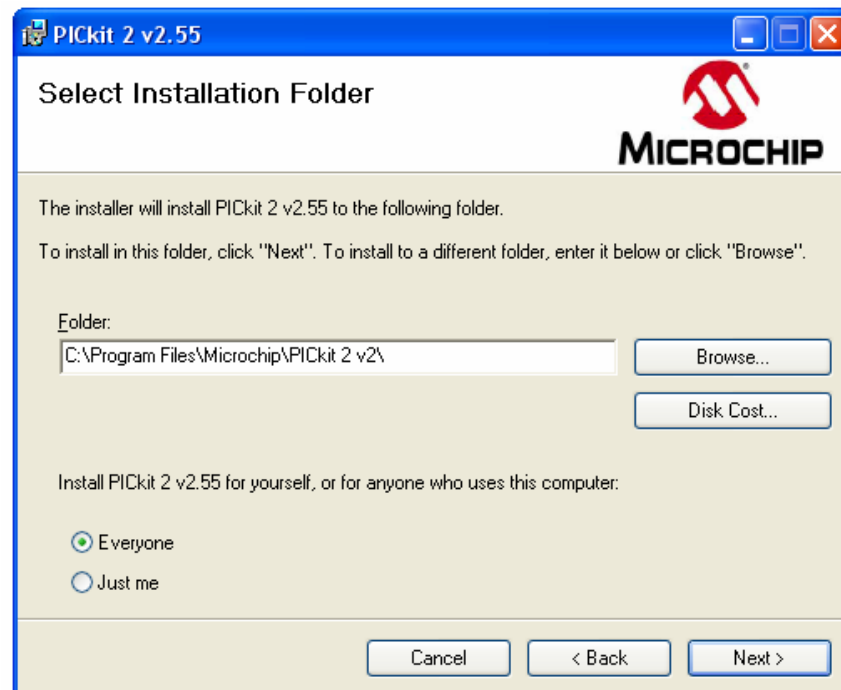

3. Click next to start the installation of the PICkit 2 programming software.

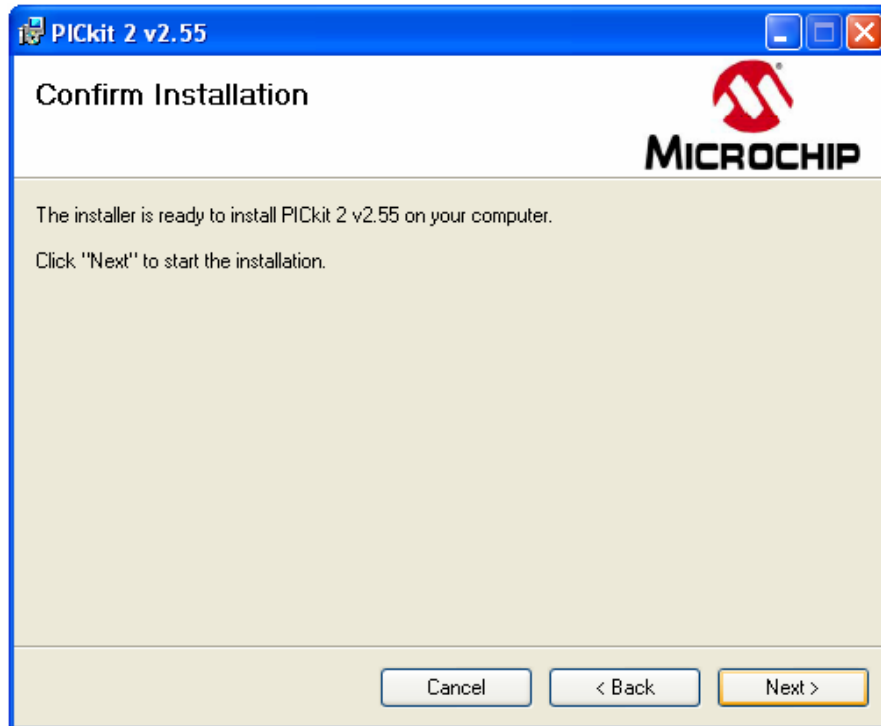

4. The following license agreement window will appear. In order to proceed with the installation, read the conditions, select the option *I Agree* and click on *Next*.

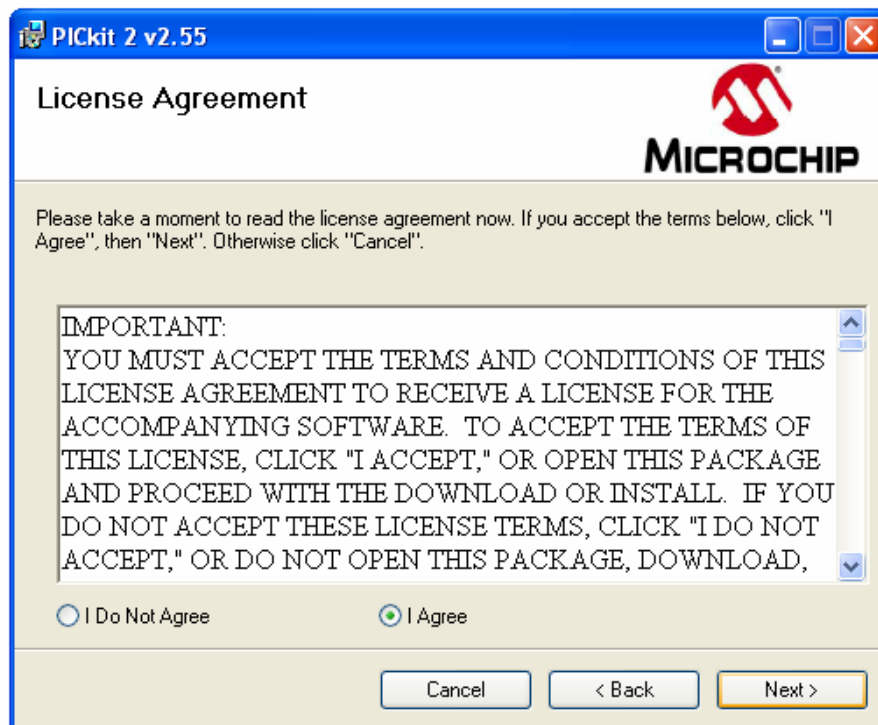

5. Wait for a while. PICkit 2 is being installed to PC.

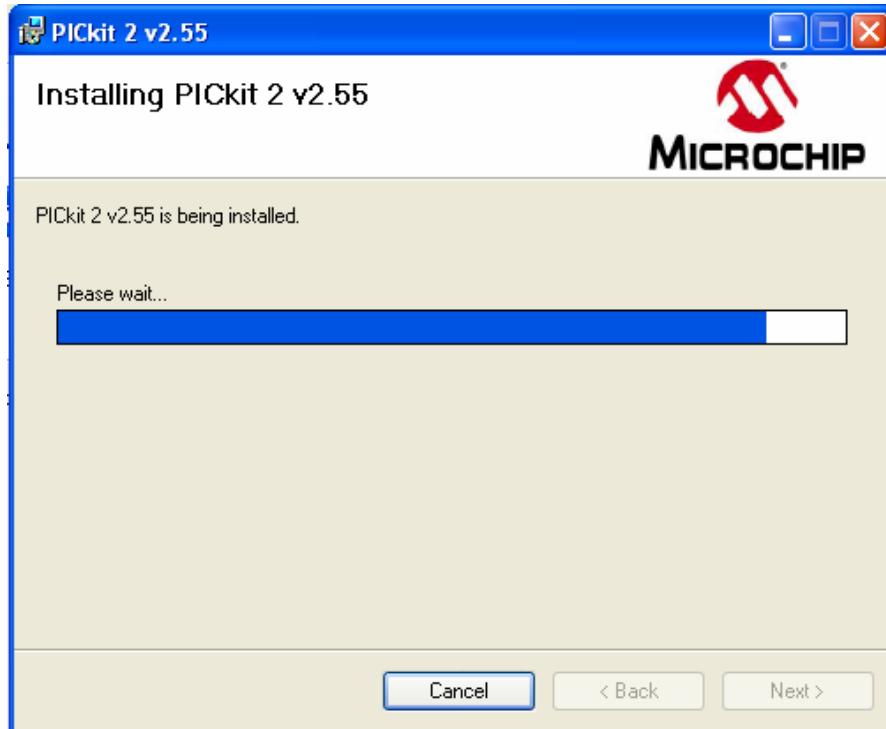

6. After complete installation, click Close to exit.

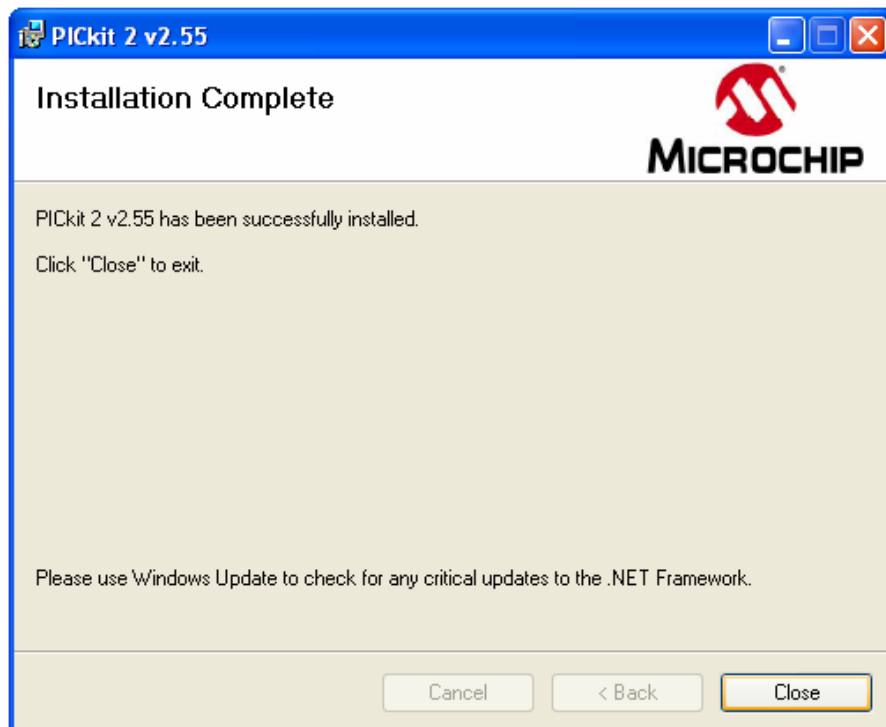

7. GETTING STARTED

7.1 Using PICkit 2 Programmer Software

After installing hardware and software in previous section, UIC00A is ready to be used with PICkit 2 programming software. This section gives instruction on how to get started with UIC00A. With the help of pictures and some simple instruction, following section illustrates the steps using UIC00A.

1. Connect the UIC00A as shown in section 5 (hardware installation).
2. Launch PICkit 2 programming software by selecting *Start > Program > Microchip > PICkit 2*.
 - The following programming interface appears and notifies that the PICkit 2 and target device found and connected.
 - This programmer is able to automatically detect PIC from connected target and display it in the *Device Configuration* window.

The screenshot shows the PICkit 2 Programmer software interface. The window title is "PICkit 2 Programmer". The menu bar includes "File", "Device Family", "Programmer", "Tools", and "Help". The "Midrange Configuration" section displays the following information:

Device:	PIC16F876A	Configuration:	2FCF
User IDs:	FF FF FF FF		
Checksum:	0FCF	OSSCAL:	
		BandGap:	

Below the configuration section, a status window displays "PICkit 2 found and connected." and "PIC Device Found." with the Microchip logo. The status bar shows "VDD Target" with a dropdown menu set to "5.0". The "Program Memory" section is enabled and shows a table of memory addresses and their corresponding hex values:

0000	3FFF	3FFF	3FFF	3FFF	3FFF	3FFF	3FFF	3FFF	3FFF
0008	3FFF	3FFF	3FFF	3FFF	3FFF	3FFF	3FFF	3FFF	3FFF
0010	3FFF	3FFF	3FFF	3FFF	3FFF	3FFF	3FFF	3FFF	3FFF
0018	3FFF	3FFF	3FFF	3FFF	3FFF	3FFF	3FFF	3FFF	3FFF
0020	3FFF	3FFF	3FFF	3FFF	3FFF	3FFF	3FFF	3FFF	3FFF
0028	3FFF	3FFF	3FFF	3FFF	3FFF	3FFF	3FFF	3FFF	3FFF
0030	3FFF	3FFF	3FFF	3FFF	3FFF	3FFF	3FFF	3FFF	3FFF
0038	3FFF	3FFF	3FFF	3FFF	3FFF	3FFF	3FFF	3FFF	3FFF
0040	3FFF	3FFF	3FFF	3FFF	3FFF	3FFF	3FFF	3FFF	3FFF
0048	3FFF	3FFF	3FFF	3FFF	3FFF	3FFF	3FFF	3FFF	3FFF
0050	3FFF	3FFF	3FFF	3FFF	3FFF	3FFF	3FFF	3FFF	3FFF
0058	3FFF	3FFF	3FFF	3FFF	3FFF	3FFF	3FFF	3FFF	3FFF

The "EEPROM Data" section is also enabled and shows a table of memory addresses and their corresponding hex values:

00	FF	FF	FF	FF	FF	FF	FF	FF	FF	FF	FF	FF	FF	FF	FF	FF	FF	FF	FF
10	FF	FF	FF	FF	FF	FF	FF	FF	FF	FF	FF	FF	FF	FF	FF	FF	FF	FF	FF
20	FF	FF	FF	FF	FF	FF	FF	FF	FF	FF	FF	FF	FF	FF	FF	FF	FF	FF	FF
30	FF	FF	FF	FF	FF	FF	FF	FF	FF	FF	FF	FF	FF	FF	FF	FF	FF	FF	FF

Buttons for "Read", "Write", "Verify", "Erase", and "Blank Check" are visible. The "VDD Target" section includes checkboxes for "Check" and "/MCLR". The "EEPROM Data" section includes a "Hex Only" dropdown and buttons for "Auto Import Hex + Write Device" and "Read Device + Export Hex File". The "PICkit 2" logo is displayed in the bottom right corner.

- If PICKit 2 Programmer does not detect the PIC automatically, user needs to help PICKit 2 Programmer to detect it manually. Click Tools and then Check Communication. PICKit 2 Programmer will detect the device and name it.

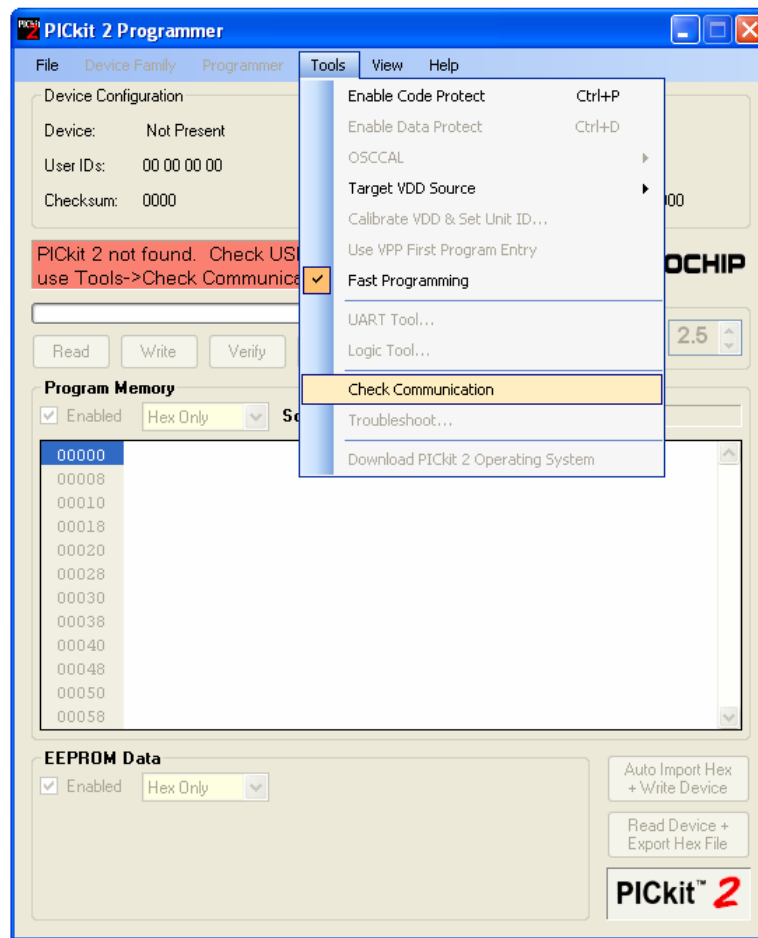

- If device is successfully detected, the device name will appear at “Device Configuration” area.
3. UIC00A can supply power to the target device. However, users are advised to power the target device externally to prevent this programmer exceed from 150mA current limit. For UIC00A, the “V_{DD} Target” will automatically be 5.0. User should power +5V to the target PIC.

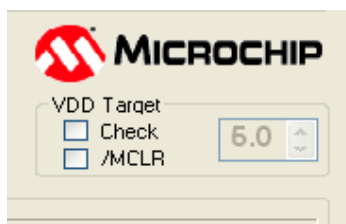

Caution: USB port current limit is 150mA. If the target and UIC00A exceed this current limit, the UIC00A board might be damaged. The target board should be powered externally. If the target device is powered externally, please DONOT connect V_{DD} (5V) of UIC00A to target PIC, only one power supply should be connected to target PIC.

4. Import the Hex file by choosing 'File' and click 'Import Hex'.

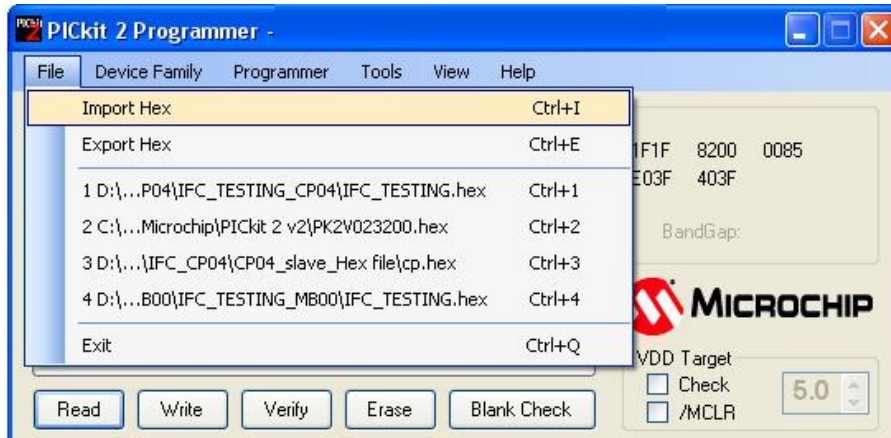

5. Browse for the Hex file location and open to start import the Hex file.

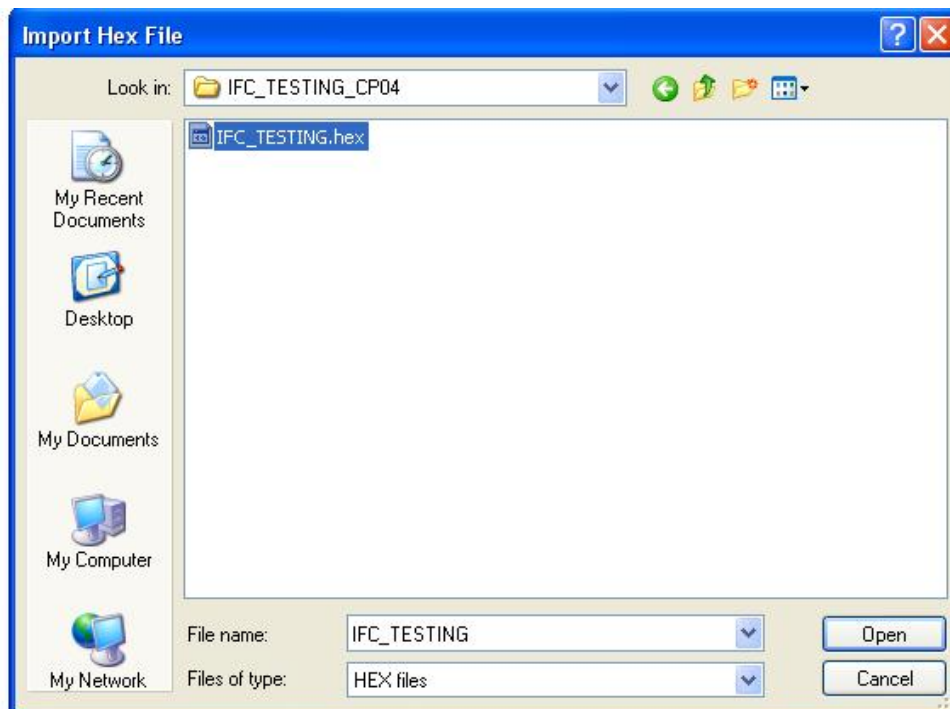

- If the Hex code is supported and match with the device, PICkit 2 Programmer will successfully import the Hex code.

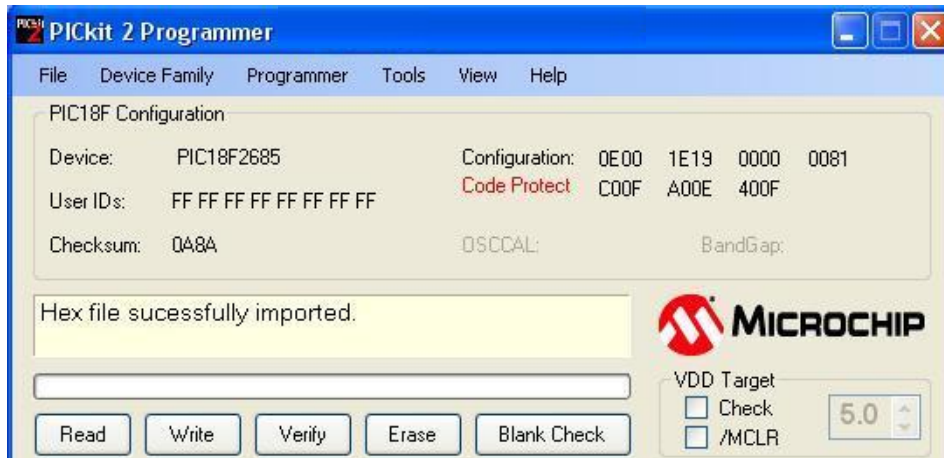

- After Hex file has been successfully imported, the target device can be programmed by clicking on *Write*. The PIC will be erased and programmed with the new Hex code imported. The operation status will display on the *Status Bar* and the status bar will turn to GREEN if writing is successful.

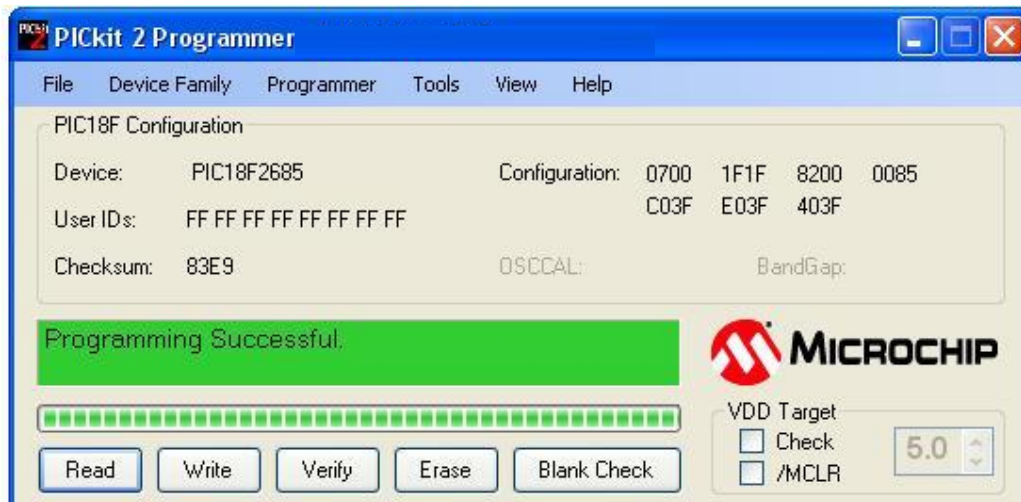

- Push button (on UIC00A main board) is a special feature to load Hex file into the target device. Push button can be used after *Programmer>Write on PICkit Button* is checked as figure below:

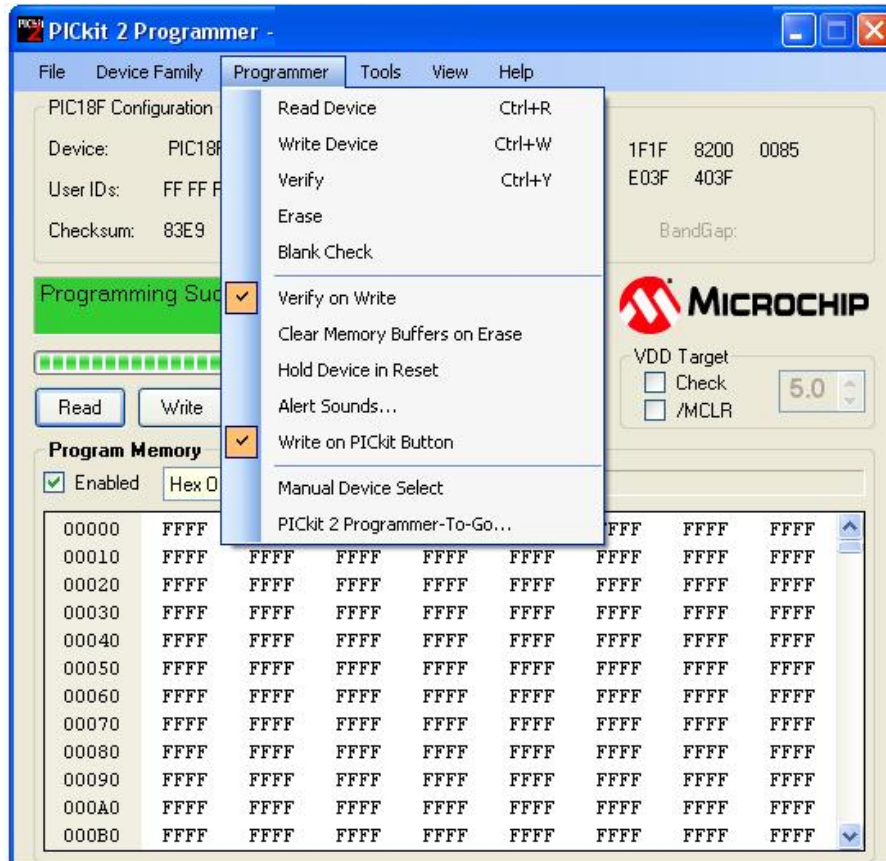

- After “Write on PICkit Button” is checked, browse for the Hex file location and open to start imported the Hex file.

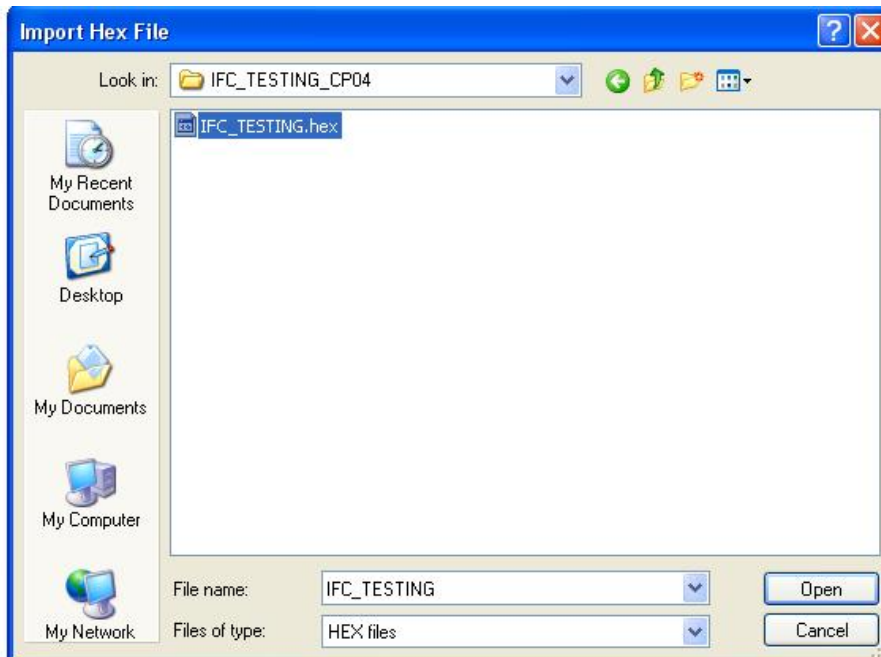

10. Press push button and the Hex file will automatically program into the target device.

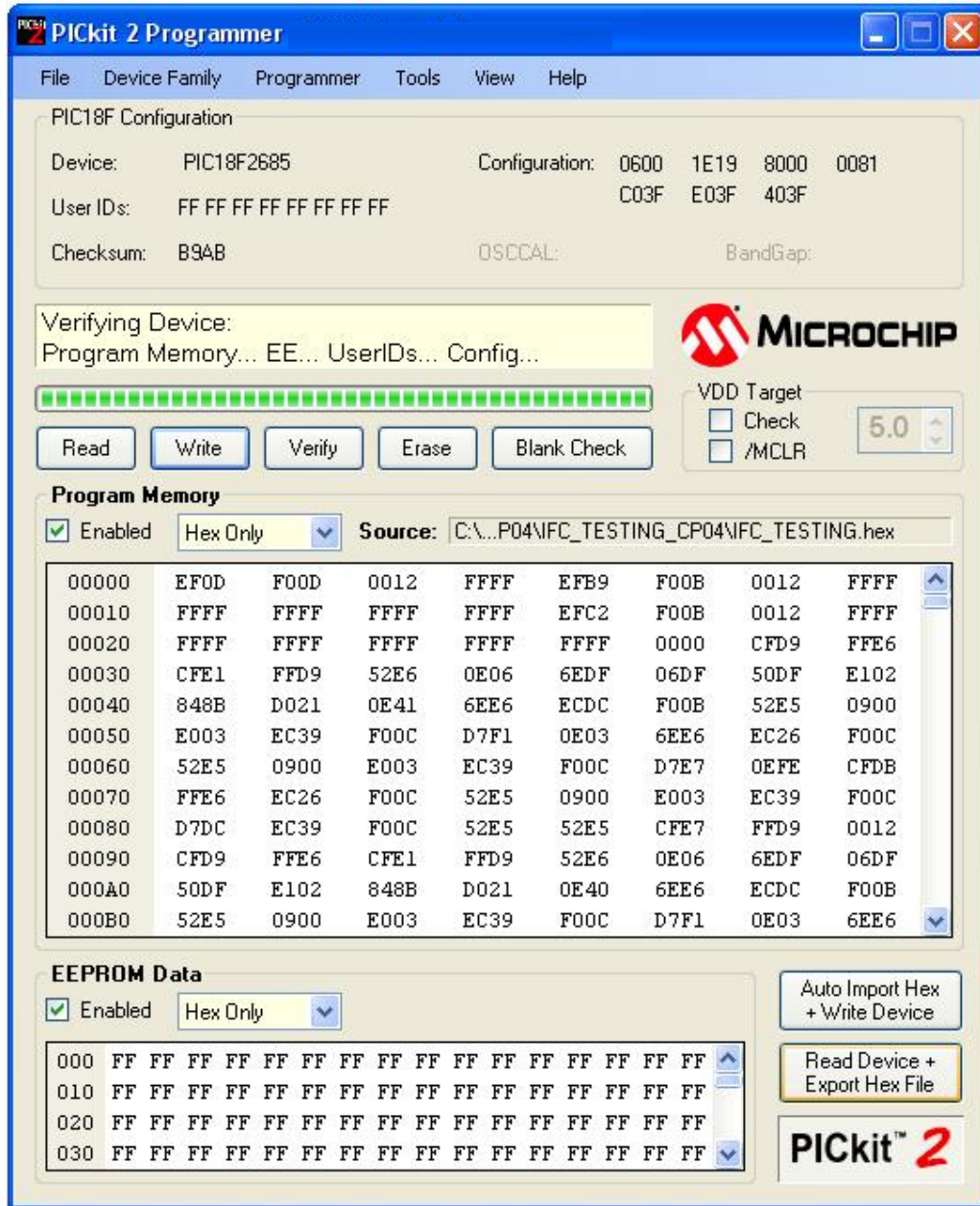

- Push button allow user to reload the updated hex file into the target device. After convert any changes in the program into Hex file, press push button again and UIC00A will automatically reload the new Hex file, further program into the target device.

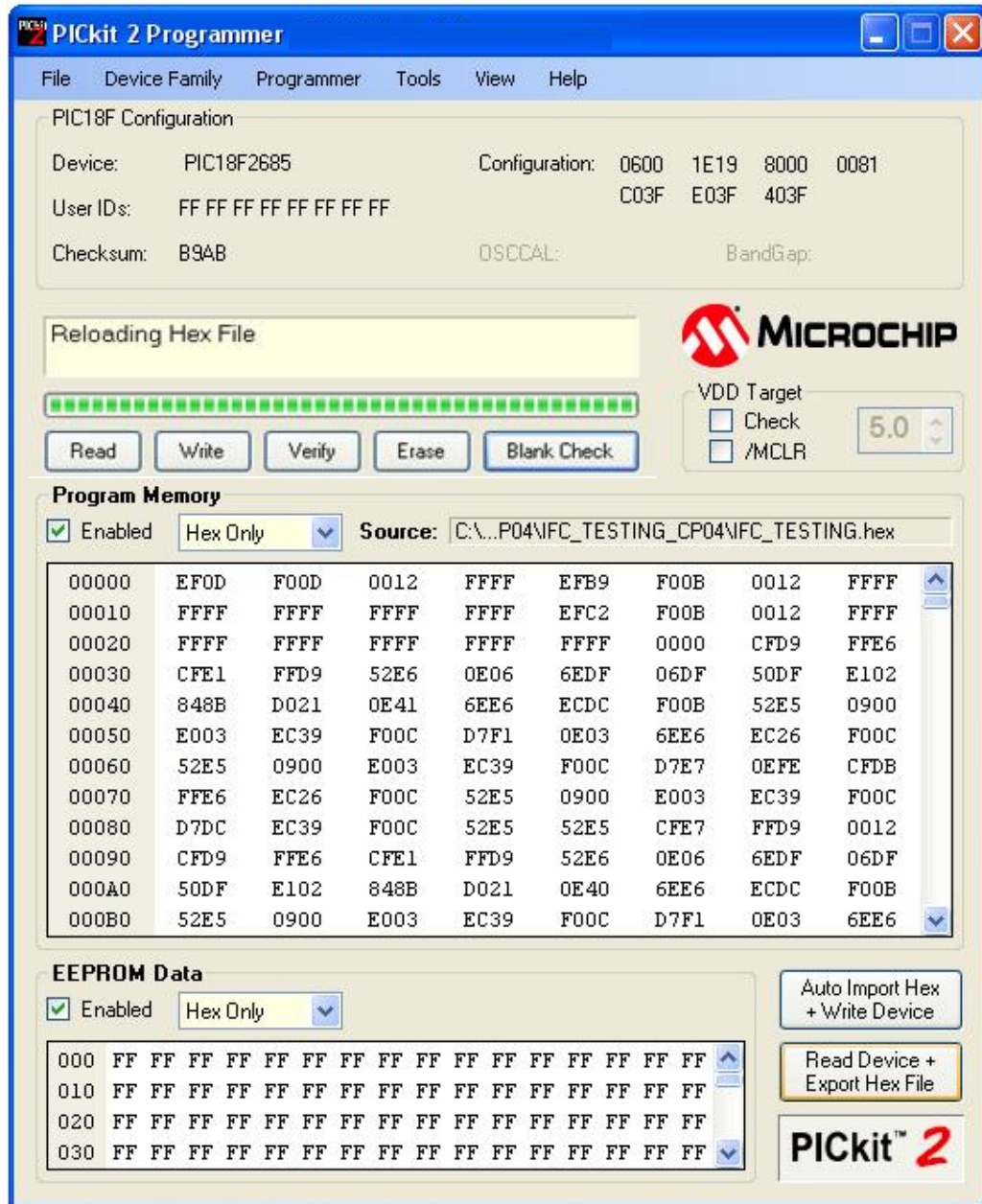

- Verify* function verify the device program to the imported Hex file. *Read* function is to view the code written to the PIC. The code will be display in the Program Memory and Data EEPROM Memory. If all zero display, it is possible that the target device is code-protected.

13. *Auto Import Hex + Write Device* allows the programmer to automatically import and write the Hex file to the connected device when the Hex file is updated, for an example on a new firmware build. By clicking this icon, it will bring up an Import Hex File dialog.



14. After selecting file, Hex code will be written to the target device and UIC00A will monitor the selected file for update. If the file is updated (after compiled), UIC00A will automatically re-imports the Hex file and writes to the target device. To disable this feature, simply click this icon again.

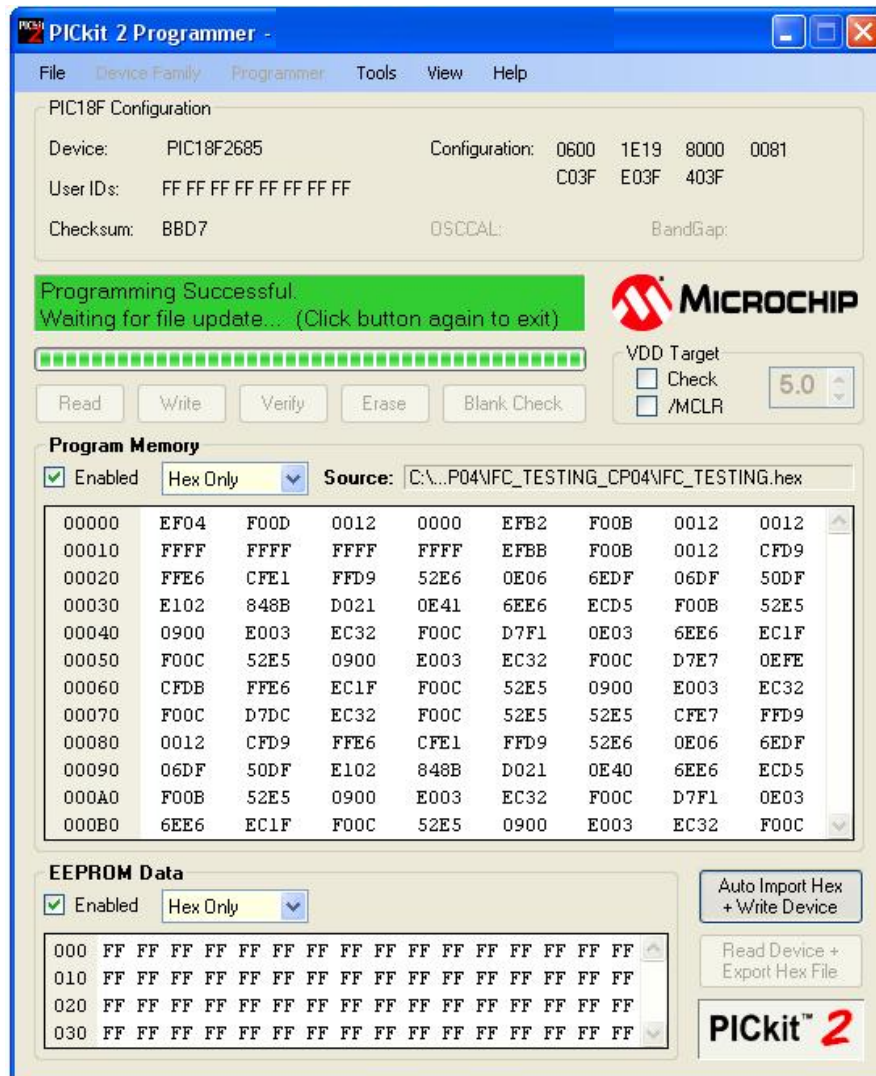

- Old UIC00A's firmware must updated in order to use with new version of PICKit 2 (2.55 version) software. The PICKit 2 software will prompt user to update the firmware.

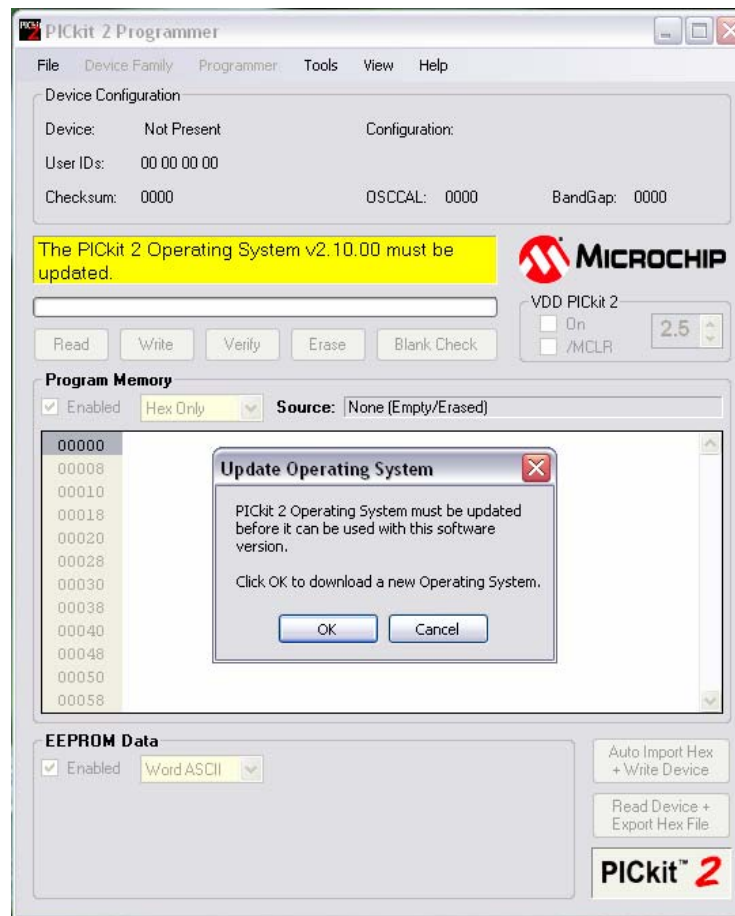

- To update the firmware for UIC00A, close PICKit 2 program and download “UIC00A Firmware Updater” from Cytron’s website under UIC00A product page.
- Double click “UIC00A Firmware Updater” and Cytron UIC00A rev1.0 Firmware Updater windows will appear as shown in figure below.

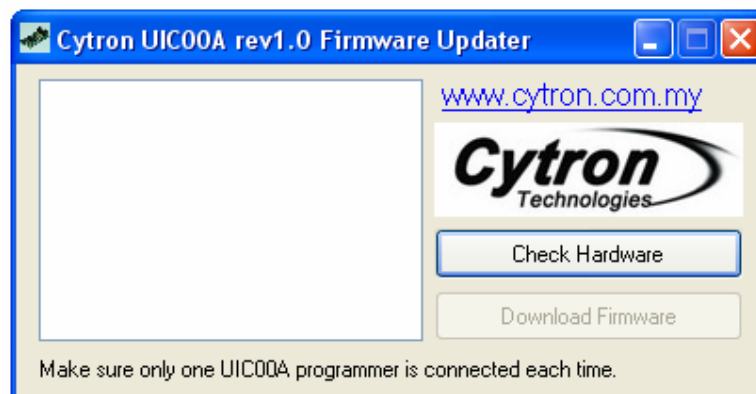

- Connect A-type USB connector (one end of USB cable) to USB port at laptop or PC desktop.
- Connect the other end of USB cable (mini) to UIC00A USB port. Green LED (Power) will turn on.
- Click on “Check Hardware”. When the operation is succeeded, Unit ID and OS Firmware will be displayed as shown in figure below. Make sure only one UIC00A programmer is connected each time.

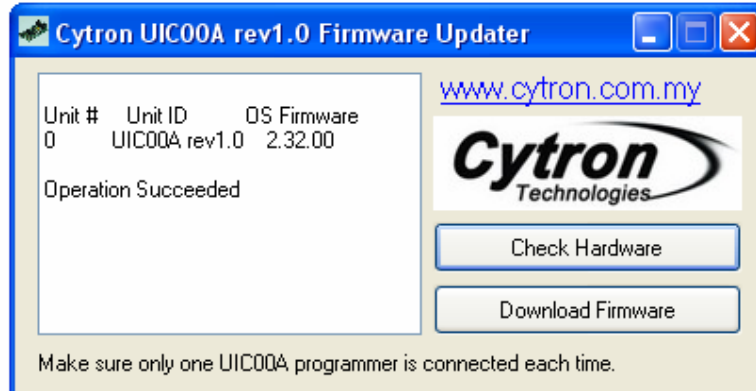

- UIC00A firmware updater will prompt a warning message if more than one UIC00A is detected at the time. Only one UIC00A programmer can be updated each time.

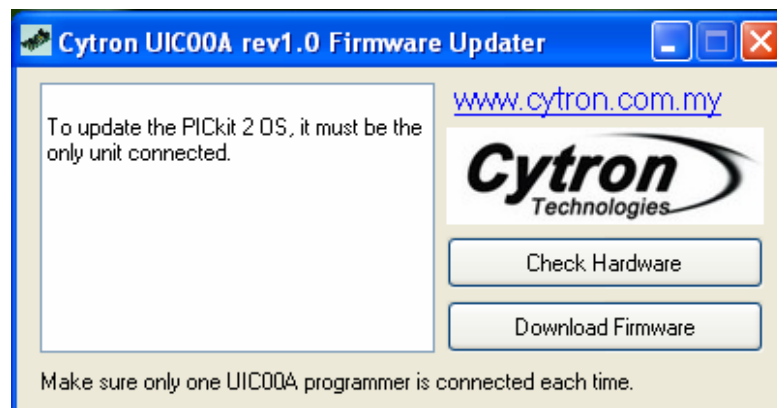

- Click “Download Firmware” to start download new firmware into UIC00A. Wait for around 30 second for the operation to complete.

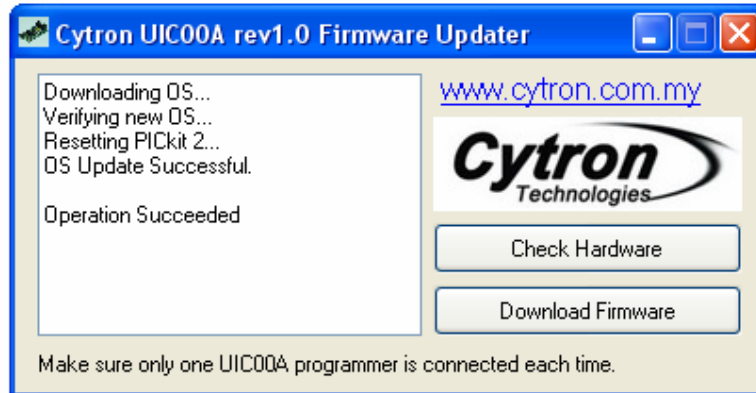

- After downloading process completed, user can use UIC00A programmer as usual. After updated the firmware, new ID will be assigned and displayed as shown in figure below.

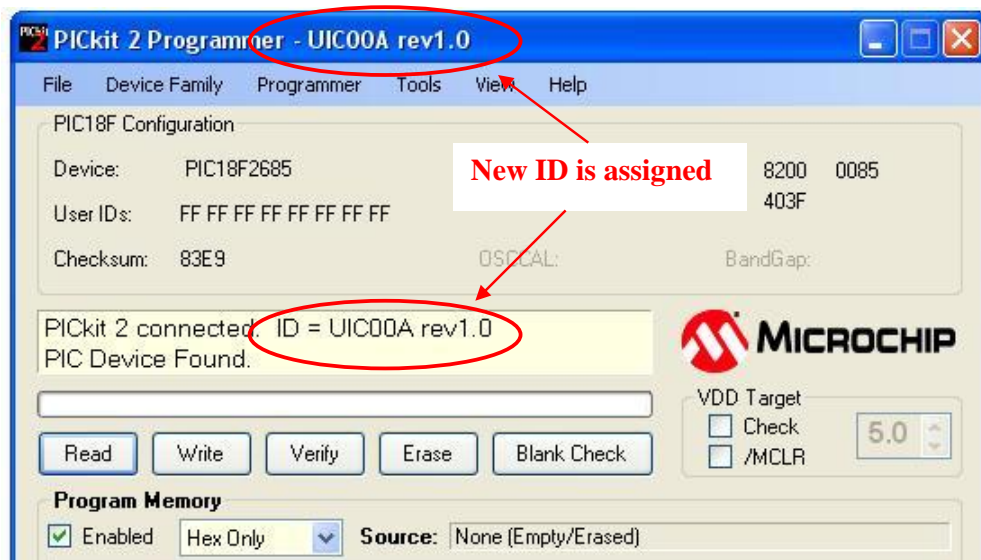

7.2 Using UIC00A

UIC00A can be used in two methods:

- 1) Program a PIC MCU with the MCU on development board which has been shown in section 5.1.
- 2) Program a PIC MCU in stand alone mode, shown in section 5.2.

7.2.1 Using UIC00A with application circuit (development board)

UIC00A can program PIC microcontroller installed in the application circuit using In-Circuit Serial Programming (ICSP). In-Circuit Serial Programming requires five signals:

- V_{PP} – Programming voltage. When applied, the device goes into programming mode.
- ICSPCLK/PGC/RB6 – Programming clock; a unidirectional synchronous serial clock line from the programmer to the target.
- ICSPDAT/PGD/RB7 – Programming data; a bidirectional synchronous serial data line.
- V_{DD} (5V) – Power supply positive voltage, it can be either from programmer or application circuit. This is optional to target PIC. If target PIC is powered externally (recommended) this pin should **NOT** be connected to target PIC.
- V_{SS} (Gnd) – Power supply ground reference.

However, the application circuit must be designed to allow all programming signals (V_{pp} , ICSPCLK/PGC/RB6 and ICSPDAT/PGD/RB7) to connect to the PIC microcontroller device without distorting the programming signals. Figure below shows a typical circuit as a starting point when designing an application circuit for the ICSP. Those unconnected pins (1, 2, 9 & 10) of Box header should be **leaved unconnected** on application circuit.

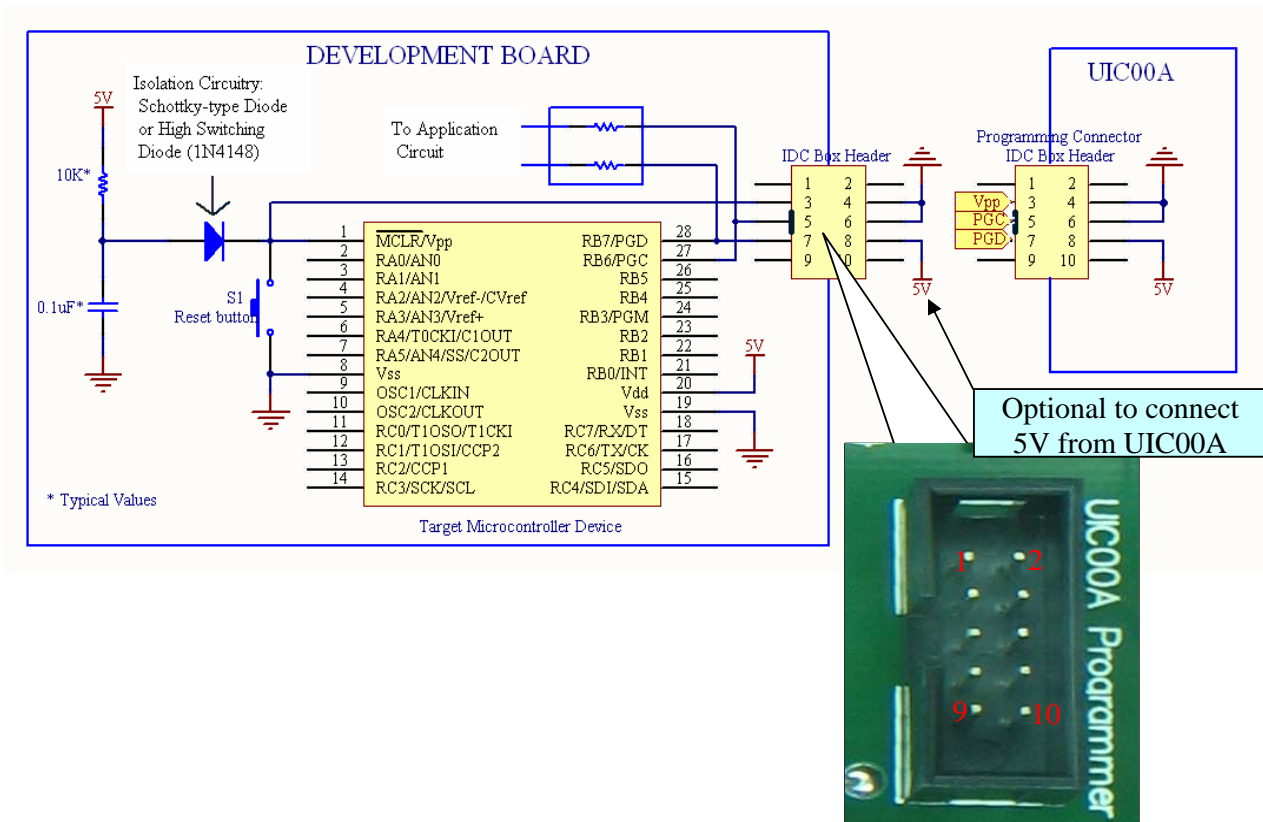

Note: PIC microcontroller in the figure above is for reference purpose only. Refer to chapter 3 for supported PIC models.

Please be aware of:

- During programming mode, V_{PP} voltage will be raised to about 13.25V. It is recommended to isolate the supervisory circuit if interfaces with MCLR pin by using Schottky-type diode or high switching diode (1N4148) to prevent V_{PP} voltage slew rate from slow down and exceeds the rise time in the programming specification (typically 1 μ s). There should **not** be capacitive component (capacitor) connected to MCLR **directly**.
- RB7/PGD or RB6/PGC pin are recommended to use as output controlling non critical device such as LED, LCD, 7 segments or buzzer. It is recommended to isolated ICSP signals from application circuit by using series resistor (range 220 ohm and above) as shown in figure above. Furthermore, **NO** capacitive component (capacitor) should be connected to these 2 pins directly.
- During ICSP programming, PIC microcontroller needs to be powered. It is recommended to power the target externally; USB is not able to support large power usage. If target PIC is powered externally V_{DD} (5V) should **NOT** be connected to target PIC.
- The **minimum connections** from UIC00A to target board or PIC are **four**. These include **Vpp, PGD, PGC** and **Vss (Gnd)**.
- Thus, the 5V from UIC00A is an **optional connection**. If user is powering up the target board with external power, this pin is not necessary to connect from UIC00A to target board.
- For usage example, please refer to DIY Project (PR7 onwards) in Cytron website.

7.2.2 Using UIC00A with UIC-S (optional, buy separately)

UIC-S is an optional socket that can be used with UIC00A to program several types of PIC microcontroller. Below are the steps of using the UIC-S and method to connect it to UIC00A:

1. Connect one side of the rainbow cable (programming cable) to box header of UIC00A board and the other side to box header of UIC-S as shown in section 5.2.
2. LED PWR of UIC-S will ON (once USB connection from UIC00A to computer or laptop is connected) indicate that the board is working correctly.
3. After that, turn the slide switch (on UIC-S) either to 18 pins or 28/40 pins (according to the PIC microcontroller that you want to program).
4. Download the program as shown in section 7.

7.3 Troubleshooting

Following section discuss error messages from PICkit 2 programming software, possible root causes and methods to fix it.

- a. Window (right bottom corner) show “Unrecognized USB device” when UIC00A is connected to USB port.
 - i) Please check the connection of your USB cable (computer and also UIC00A).
 - ii) Please try to use other USB cable.
 - iii) Please try other USB port on computer.
 - iv) Please try on other computer.
 - v) If the problem still occur, please contact Cytron at support@cytron.com.my
- b. Status Window shows: “PICkit 2 not found. Check USB connections and use Tools->Check Communication to retry”.
 - i) Please reconnect the UIC00A to USB port and try again.
 - ii) Driver might not be installed properly, uninstall driver and install again.
 - iii) User might need to update Operating System. Please refer to step 14 of chapter 7.
 - iv) Check the power LED on UIC00A. If it is Off, UIC00A have hardware problem.
- c. Status Window shows: “No device detected” while Device shows: “No Device Found”.
 - i) Please ensure the target PIC is powered with typical voltage of 5V for Vcc.
 - ii) Please ensure the **PGC and PCD** is connected to correct pin on target PIC.
 - iii) Please ensure the Vss (Gnd) of UIC00A and target PIC is common (connected).
- d. Device shows: “Unsupported part”.
 - i) Please ensure the Vss (Gnd) of target PIC is connected.
 - ii) Please ensure the target PIC is in supported list.
- e. A small message window shows: “PICkit 2 VPP voltage level error. Check target & retry operation”.

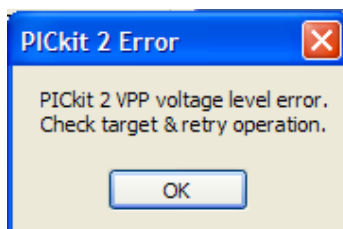

- i) Check MCLR pin of target PIC, it must **not** pulled to ground during programming.
 - ii) Check MCLR pin of target PIC, there should not be capacitor connected.
- f. When UIC-S is plug in Green LED at UIC00A is ON but Green LED and UIC-S is not ON.
 - i) UIC00A on board fuse is burned, there might be some place shorted causing this. Please send back for repair, service shipping charges will be required.
 - ii) PIC chip spoilt causing short at Vdd (5V) and Vss (Gnd). Change PIC.
 - iii) Check the back of UIC-S for any wire or dirt which might be causing the short.

For any feedbacks and inquiries, please send an email to support@cytron.com.my

8. WARRANTY

- Product warranty is valid for 6 months.
- Warranty only applies to manufacturing defect.
- Damage caused by misuse is not covered under warranty.
- Warranty does not cover freight cost for both ways.

Prepared by
Cytron Technologies Sdn. Bhd.
19, Jalan Kebudayaan 1A,
Taman Universiti,
81300 Skudai,
Johor, Malaysia.

Tel: +607-521 3178

Fax: +607-521 1861

URL: www.cytron.com.my

Email: support@cytron.com.my

sales@cytron.com.my